



Presents

A CALL TO ARTISTS

for

Solo Exhibition

during the Pop Art Show

Feature Foyer

The Solo Exhibition Open Call gives artists the opportunity to present 10-14 pieces in the Feature Foyer Gallery. We are looking for Pop Art, Pop Surrealism or Low Brow works to complement the Pop Art Show. Any medium is acceptable. Our Feature Foyer faces our front window and provides a great opportunity to gain exposure.

Important Dates

Exhibition Dates:March 27 – April 25, 2020

Deadline to enter: December 13, 2019

Artist Notification: December 20, 2019

Shipping deadline of work to Blue Line Arts: March 19, 2020

Hand deliver work to Blue Line Arts:.....March 22 or 23, from 10 am - 3 pm

Opening Reception:April 18, from 5 pm - 8 pm

Pick up unsold work from Blue Line Arts: April 26 and 27, 10 am - 3 pm

Eligibility

- Open to all artists.
- All artwork must be original and completed within the last two years
- Artwork cannot have been previously exhibited at Blue Line Arts
- All artwork must be for sale
- Accepted artwork that differs significantly from image in online submission will be disqualified
- No accepted entry may be withdrawn or sold outside of the exhibition prior to the closing date
- All artwork must be ready to hang
 - **No sawtooth hangers;** artworks must have wire installed to hang
- Pedestals or shelves are available for three-dimensional work

Pricing Agreement

Blue Line Arts handles all sales transactions. *The artist agrees that the price submitted in this form will be the price that the work will be sold for and may not change hereafter.* Please note, Non-members receive a 50% sales commission and current Artist Members receive a 60% sales commission.

Shipping

The artist is responsible to pay for all shipping and should have a **prepaid label** from FedEx or UPS (No US Mail) for the return of artwork. Please mark the outside of your box with your last name in bold letters also please use blue painters tape when you wrap your artwork inside the box.

- Please refer to this link when packing your work.
https://www.fedex.com/downloads/howtopack/HowToPack_EMEA_eng_final_Feb23_2010.pdf

Application Requirements: Applicants must apply using the form on the Blue Line Arts website, <http://www.bluelinearts.org/call-to-artists>. You must be 18 years or older to apply. There is a \$35 fee for non-members, members may apply for free. You must include 10 examples of work.

Questions: If you have any questions about submissions, please contact Blue Line Arts staff during open hours at (916) 783-4117 or email Tony at tony@bluelinearts.org

Feature Foyer Dimensions:

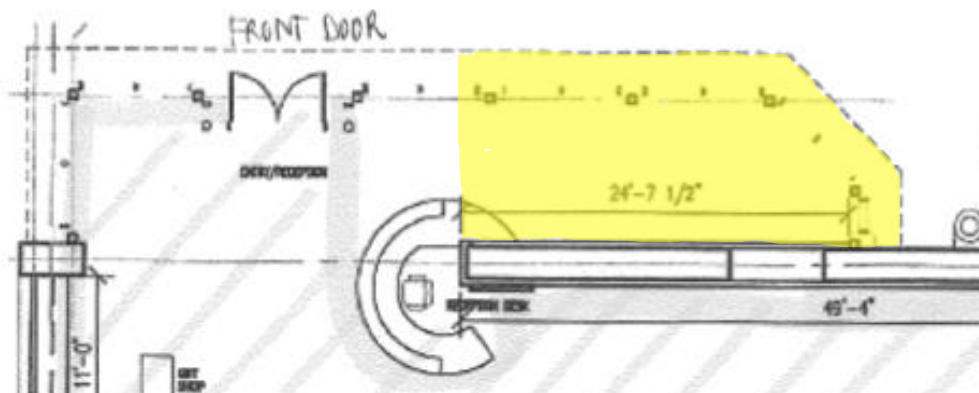

- Wall dimensions: 24 ft long, 7 ½ ft tall
- Pedestals available if needed